

STEK

ViSMART-MG

Virtualized Technology Assisted Situational Awareness and Multilayer Resilient Control for Microgrids

Duration 4.2026-4.2030

1 Million Euro

University of Vaasa

Mike Mekkanen Senior Researcher / Associate Professor



PRIMARY CONSORTIUM

Tampere University (TAU)

Dr. Hamed Badihi, Dr. Azwirman Gusrialdi

University of Vaasa (UVA)

Dr. Mike Mekkanen



Project Overview

What is ViSMART-MG?

- ViSMART-MG develops advanced virtualization technologies to enhance situational awareness and resilient control for microgrids.
- The project addresses critical challenges in integrating renewable energy sources while maintaining grid stability and reliability.

Key Objectives

- Virtualized monitoring and control systems
- Enhanced situational awareness
- Multi-layer resilient control architecture
- Seamless renewable integration

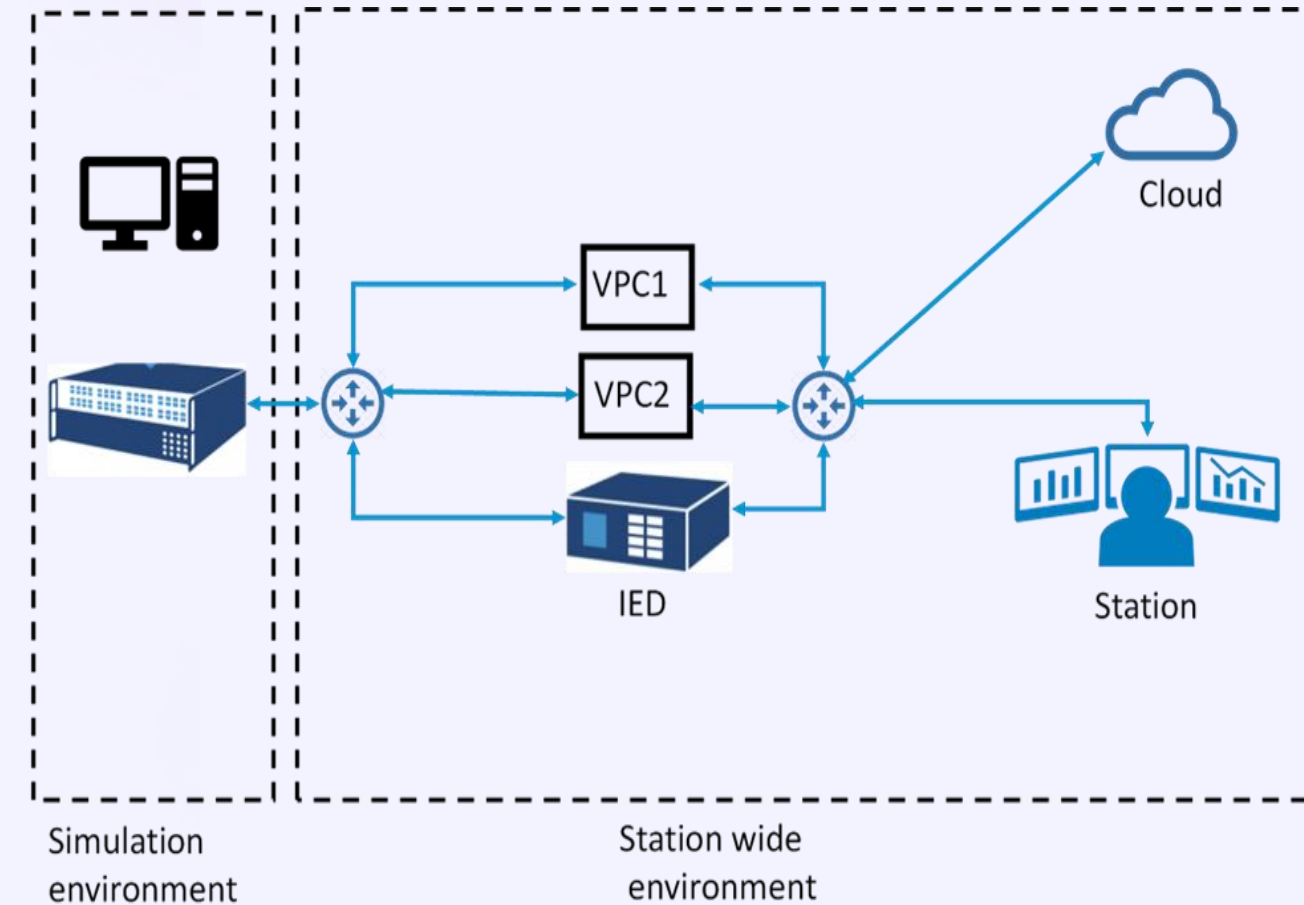

Technology Components



Virtualization Layer

Software-defined infrastructure enabling flexible resource allocation and real-time monitoring across distributed microgrid components



Resilient Control

Multi-layer control architecture with redundancy and self-healing capabilities to maintain operations during disturbances



Situational Awareness

Advanced sensors and data analytics providing real-time visibility into grid conditions and predictive insights for operators

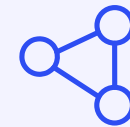

Integration Platform

Unified interface connecting diverse energy sources, storage systems, and loads for coordinated management



ViSMART-MG

01

Data Collection

Sensors gather real-time measurements from all grid components

02

Virtual Processing

Cloud-based analysis and virtualization of control functions

03

Situational Assessment

XAI algorithms evaluate grid state and identify potential issues

04

Resilient Response

Distributed control actions maintain stability across multiple layers

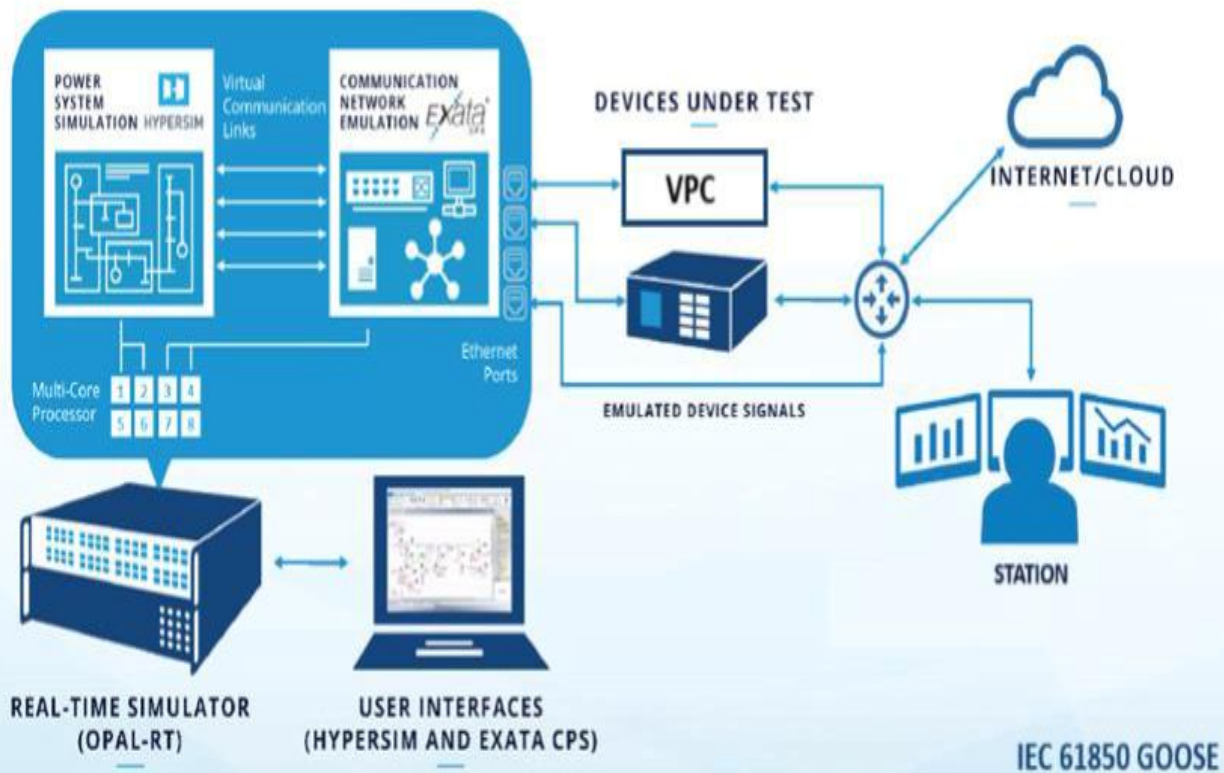

TECHNICAL APPROACH: WORK PACKAGES (WP1-WP6)



WP1: System Architecture & Resilience Baseline

Establish the foundational architecture for microgrid resilience, baseline performance metrics, and map detailed requirements across hardware and software levels.



WP2: Situational Awareness

Implement hybrid monitoring frameworks utilizing machine learning and real-time Digital Twins for advanced anomaly detection and state estimation.



WP3: Resilient Distributed Control

Develop resilient control algorithms utilizing fault- and attack-tolerant control methodologies combined with embedded safety-assured filters.



WP4: Virtualized Protection & Automation

Design and implement software-defined protection schemes leveraging standardized IEC 61850 communication protocols for flexible microgrid defense.



WP5: Operating Models & Value Chains

Formulate innovative business models, governance structures, and ecosystem expansion strategies to support resilience-as-a-service commercialization.



WP6: System Integration & Validation

Conduct comprehensive real-time Hardware-in-the-Loop (HIL) demonstrations and pilot testing to validate integrated components, achieving target TRL-6.

Research Focus Areas

Virtualization Technologies

Developing software-defined approaches to decouple physical infrastructure from control systems, enabling flexible resource management and rapid reconfiguration

Situational Awareness Systems

Creating advanced monitoring solutions that provide comprehensive visibility into microgrid operations through integrated sensor networks and data fusion techniques

Resilient Control Architecture

Designing multi-layer control frameworks with built-in redundancy, fault tolerance, and self-recovery mechanisms to ensure continuous operation during disturbances

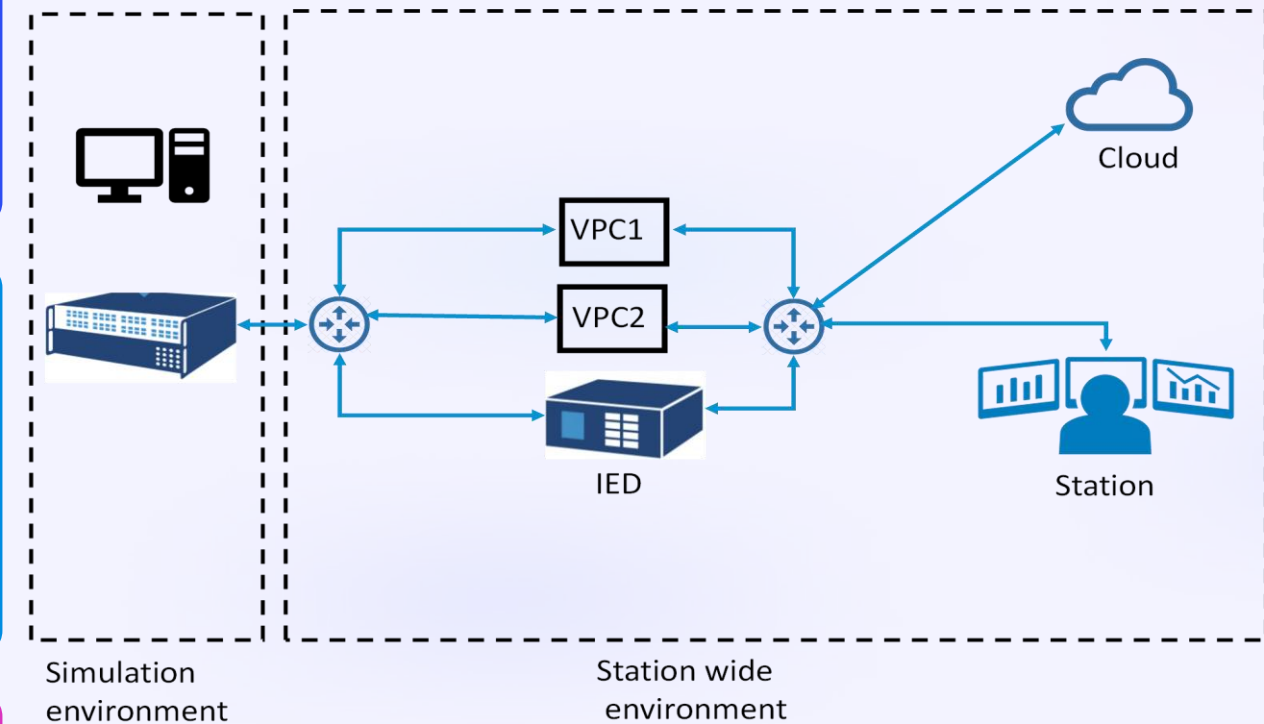

Applications & Impact

Renewable Integration

Seamlessly integrating solar, wind, and other renewable sources into stable microgrid operations

Grid Resilience

Enhancing reliability during extreme weather events and grid disturbances Hybrid-attacks

Energy Efficiency

Optimizing energy flow through intelligent control VPC

Target Applications

- Remote community microgrids
- Industrial campus energy systems SoC
- Emergency backup power networks

Expected Outcomes

- Improved grid stability
- Reduced operational costs
- Enhanced renewable utilization

